



JUKI
Union Special

STYLES

ILLUSTRATED PARTS LIST

FS311L41

FS300 SERIES, DIFFERENTIAL FEED,
HIGH SPEED FLAT BED MACHINES

CATALOG NO.
PT0105

FIRST EDITION
SUPPLEMENT TO
PT9808

03/22/05

SPREADER ADJUSTMENTS

1) Timing

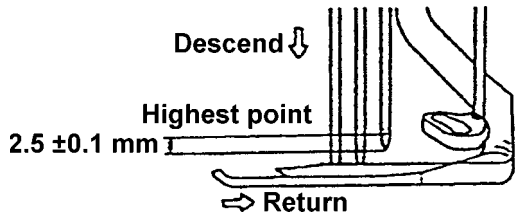

Just when the needle descends 2.5 mm from the highest point of the needle bar, the spreader begins to return from its extreme left position.

2) Stroke

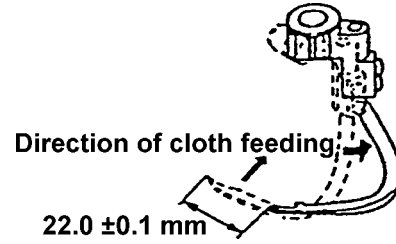

3) Position of spreader

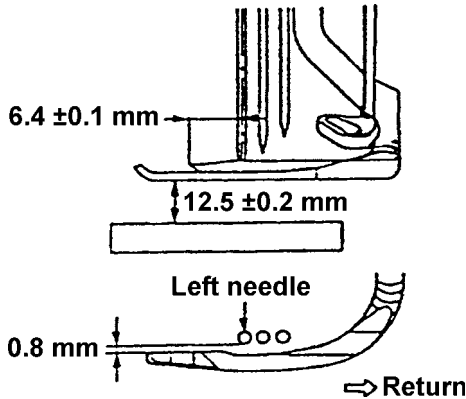

- The height is 12.5 ± 0.2 mm
- When the spreader is in the extreme left position, the distance between the center of the left needle and the top blade of the spreader is 6.4 ± 0.1 mm.
- When the spreader returns to the right, the clearance between the spreader and the left needle is 0.8 mm.

4) Fixing spreader thread guide

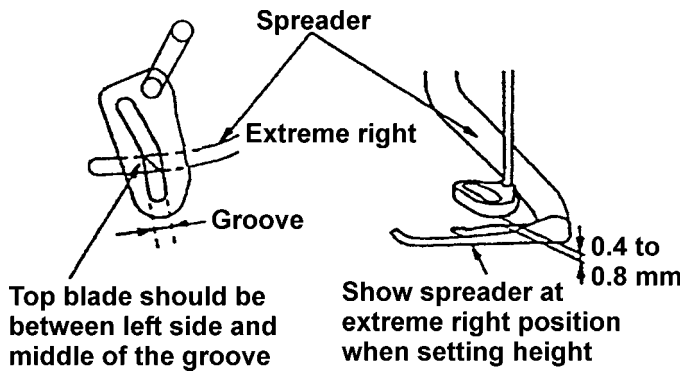

- When the spreader is in the extreme right position, the top blade of the spreader should be between the left side and middle of the spreader thread guide groove.
- The height is 0.4 to 0.8 mm from the surface of the spreader.

5) Needle clamp spreader thread guide

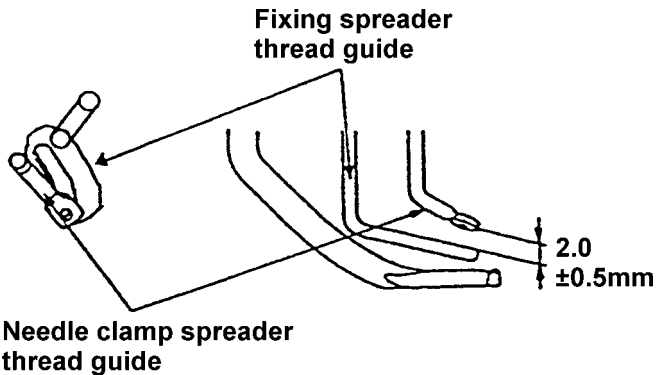

- When the needle bar is in the lowest position, the clearance between the needle clamp spreader thread guide and the upper face of the fixing spreader thread guide is 2.0 ± 0.5 mm.
- The center of the hole of the thread guide aligns with the left side of the fixing spreader thread guide groove.

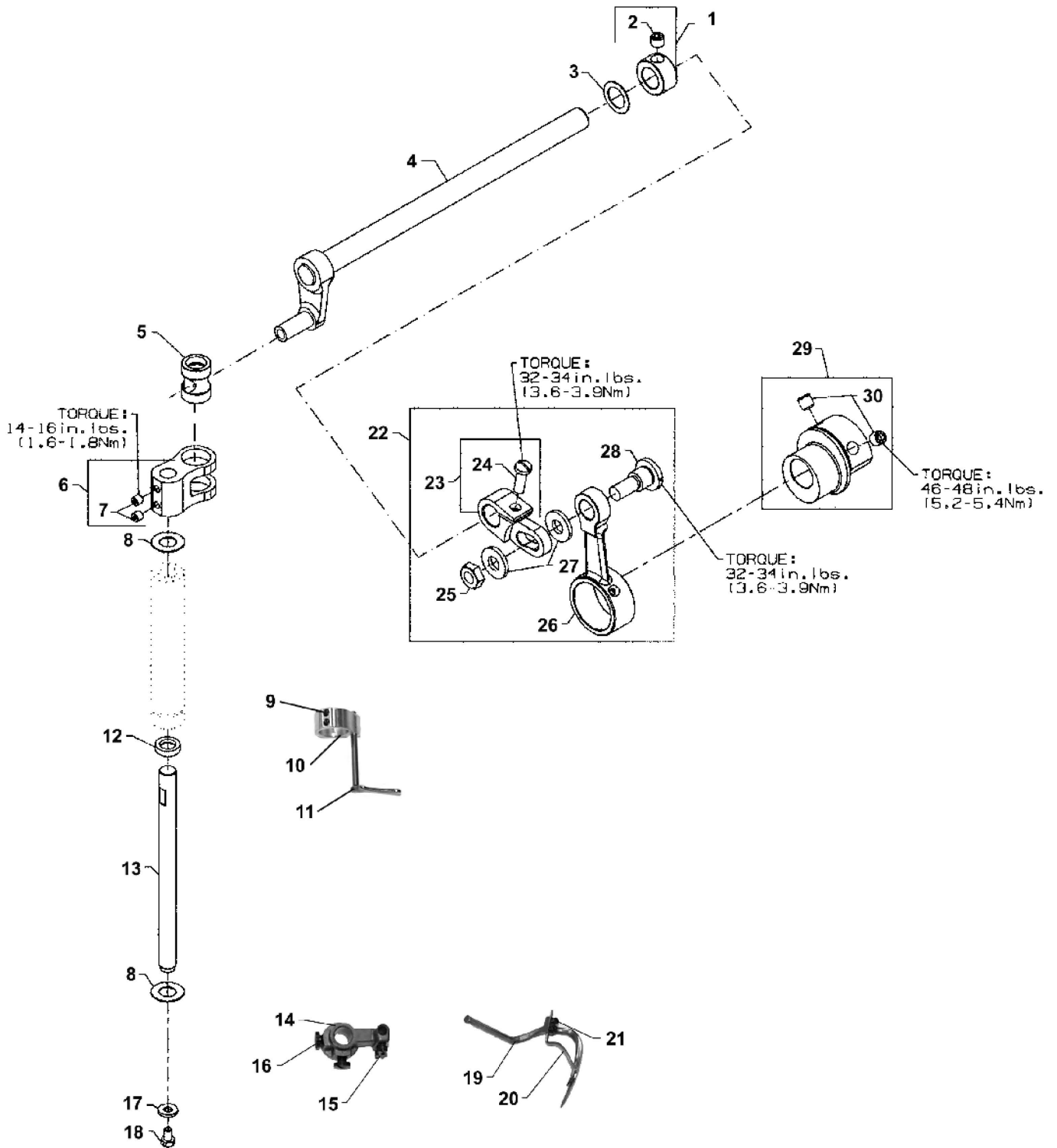

SPREADER

Ref. No.	Part No.	Description	Amt. Req.
1.	50335AW	Collar, for spreader shaft	1
2.	SS8660512TP	Set Screw	1
3.	96162B	Washer	1
4.	50360B	Crankshaft, for spreader assembly	1
5.	50347J	Pin, for spreader rocker	1
6.	50347C	Lever, for spreader holder shaft	1
7.	SS8110422TP	Screw	2
8.	61351C	Washer	2
9.	SS8080310TP	Screw	3
10.	K74382	Collar	1
11.	57845E	Spreader Thread Guide	1
12.	660-739	Oil Seal	1
13.	50347G	Shaft, for spreader, vertical	1
14.	57845G	Spreader Holder	1
15.	77	Screw	2
16.	94	Screw	2
17.	53678N	Washer	1
18.	SS9090640SP	Hex Screw, for vertical shaft	1
19.	K74383	Spreader	1
20.	57845F	Auxiliary Spreader	1
21.	22738B	Screw	2
22.	29126FW	Spreader Crank Rod Assembly	1
23.	50360G	Spreader Shaft Driving Arm	1
24.	SS7121410TP	Screw	1
25.	NS6680410SP	Hex Nut, for spreader drive	1
26.	50360F	Connecting Rod, for spreader drive	1
27.	WP0742016SP	Collar, for spreader driving arm	2
28.	SD1000801SH	Stud	1
29.	50360	Eccentric, for spreader drive	1
30.	SS8660612TP	Screw	2

***NOTE: SOME "K" PARTS SHOWN ARE NOT PICTORIALY CORRECT**



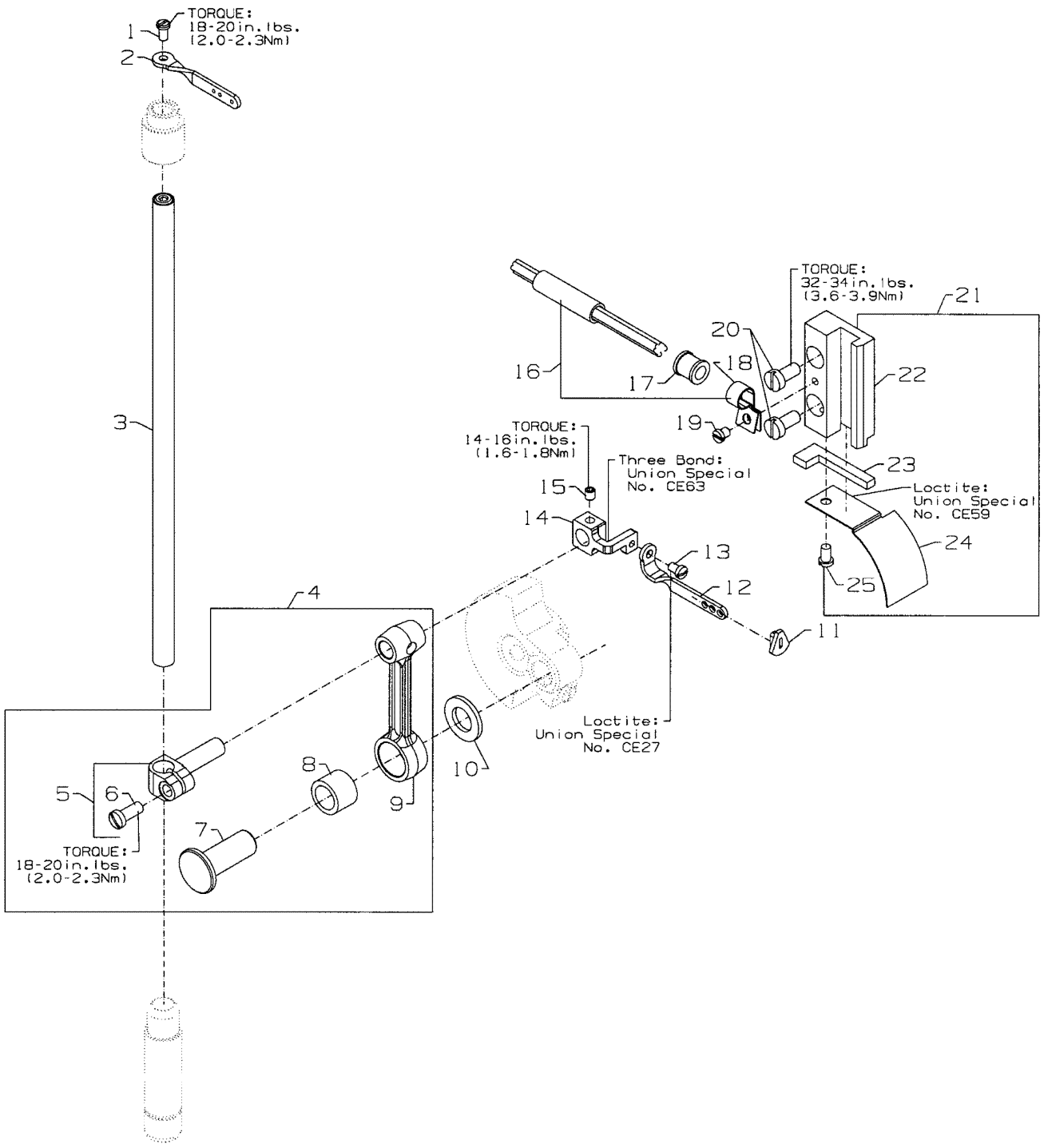

From the library of: Diamond Needle Corp



NEEDLE BAR

Ref. No.	Part No.	Description	Amt. Req.
1.	SS4080620TP	Screw	1
2.	50323P	Needle Bar Eyelet	1
3.	K74313	Needle Bar	1
4.	50645A	Connecting Rod Assembly	1
5.	50355AM	Needle Bar Clamp	1
6.	SS7111120TP	Screw	1
7.	50352	Pivot Pin	1
8.	661-259B	Needle Bearing Cage	1
9.	50645	Connecting Rod	1
10.	50351A	Washer	1
11.	50393JP	Eyelet Seal	1
12.	50358X	Needle Thread Eyelet	1
13.	SS7080520SP	Screw	1
-	CE27	Loctite Adhesive, (not shown), for screw	-
14.	50354F	Slide Block	1
-	CE63	Three Bond Adhesive, (not shown), for slide block	-
15.	SS8110422TP	Screw	1
16.	29476TC	Oil Tube Assembly	1
17.	50393JZ	Oil Tube	1
18.	50393JW	Hose Clamp	1
19.	SS6090440SP	Screw, for oil tube assembly	1
20.	SS6121010SP	Screw	2
21.	29476VN	Slide Block Guide and Cover Assembly	1
22.	50338	Guide, for slide block	1
23.	666-328	Felt, for slide block	1
-	CE59	Loctite Adhesive, (not shown), for felt	-
24.	50338A	Cover, for guide	1
25.	SS6090620SP	Screw	1

***NOTE: SOME "K" PARTS SHOWN ARE NOT PICTORIALY CORRECT**



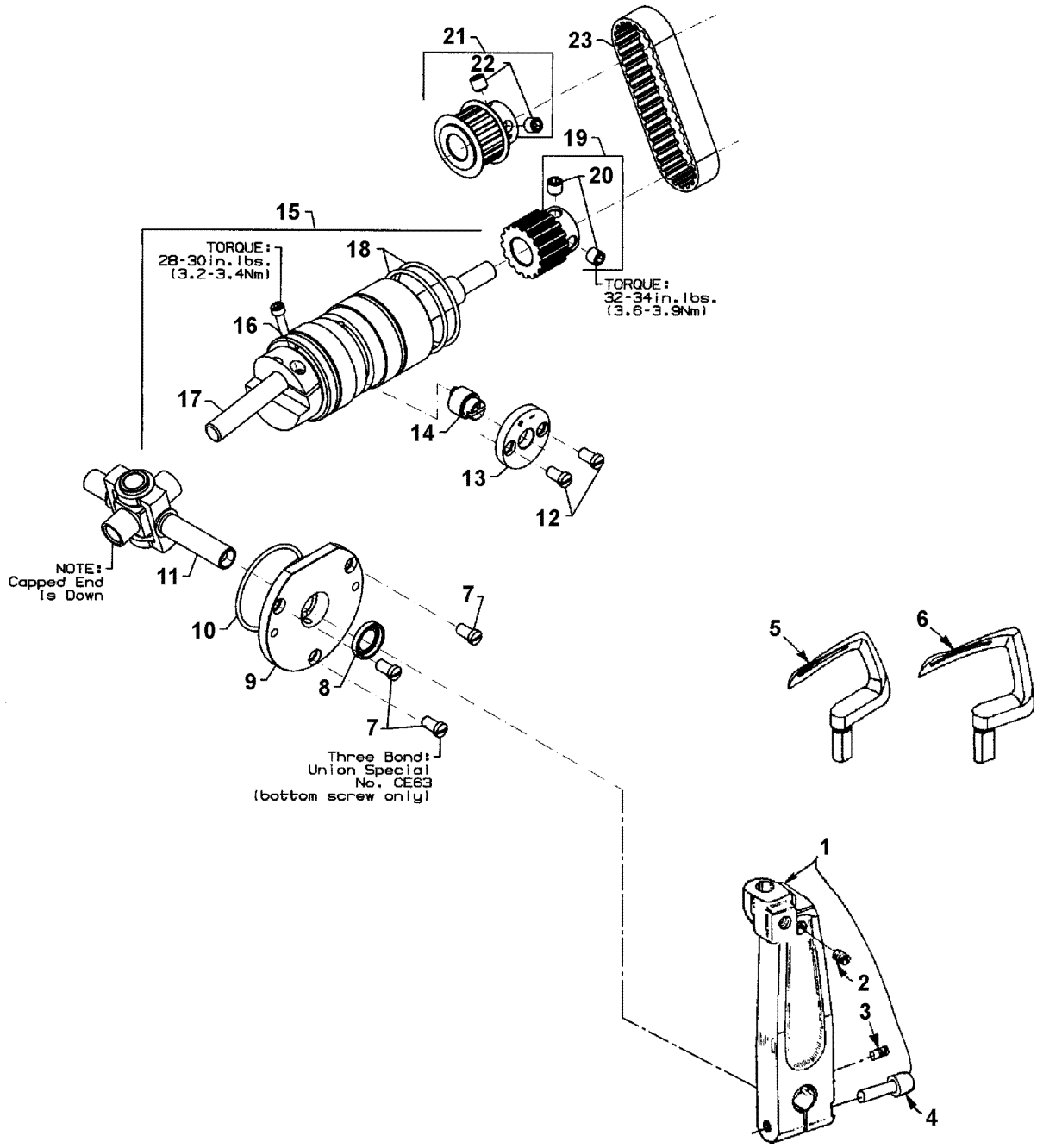

LOOPER DRIVE

Ref. No.	Part No.	Description	Amt. Req.
1.	50313F	Looper Holder	1
2.	22565X	Screw, for looper holder	1
3.	22575B	Screw, for looper holder	2
4.	22652B10	Screw, for looper holder	1
5.	50309H	Looper, Rear	1
6.	51508BV16	Looper, Front	1
7.	SS7120910SP	Screw, for bearing housing	3
-	CE63	Three Bond Adhesive, (not shown), for screw	-
8.	660-893	Oil Seal, looper	1
9.	50344AM	Bearing Housing Assembly, for looper drive	1
10.	660-455	"O" Ring, for bearing housing assembly	1
11.	50313J	Looper Rocker Assembly	1
12.	SS7120910SP	Screw, for retaining plate	2
13.	50314F	Eccentric Retaining Plate	1
14.	50314E	Looper Avoid Adjusting Eccentric	1
15.	50642	Looper Drive Assembly	1
16.	22653J8	Screw	1
17.	667J33	Crank Pin	1
18.	660-979	"O" Ring	2
19.	50342BJ	Sprocket, for looper driven	1
20.	SS8660612TP	Screw	2
21.	50342BK	Sprocket, for looper drive	1
22.	SS8660612TP	Screw	2
23.	50324BP	Looper Drive Belt	1

***NOTE: SOME "K" PARTS SHOWN ARE NOT PICTORIALY CORRECT**



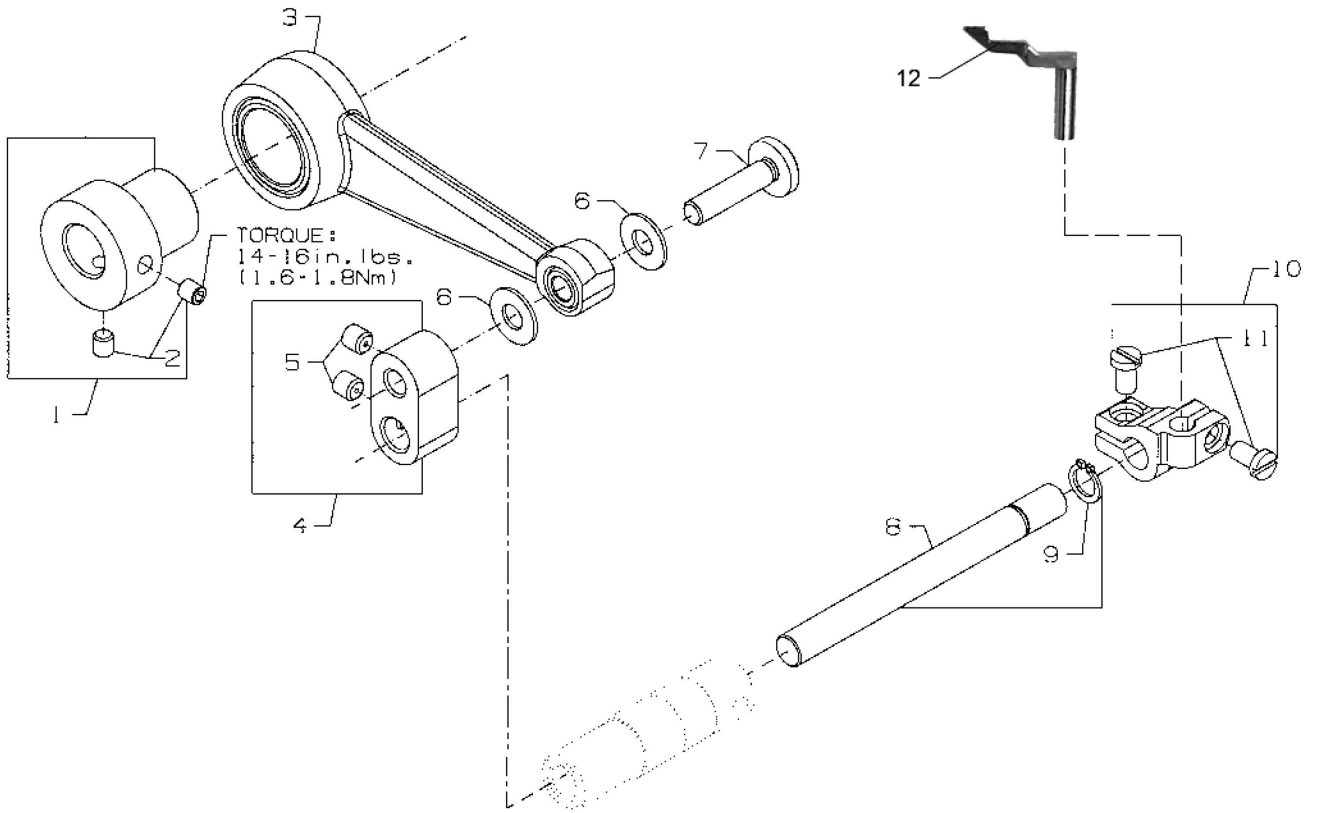

NEEDLE GUARD

Ref. No.	Part No.	Description	Amt. Req.
1.	50373DA	Needle Guard Eccentric	1
2.	SS8110422TP	Screw, for needle guard eccentric	1
3.	50368W	Connecting Rod Assembly, for needle guard	2
4.	50668	Pivot Link	1
5.	SS8110422TP	Screw	1
6.	50368E	Washer	2
7.	50368A	Pivot Pin	2
8.	50622C	Shaft, for needle guard	1
9.	RC0560711KP	Retaining Ring	1
10.	50625	Holder, for needle guard	1
11.	SS6090620SP	Screw	2
12.	50325L	Needle Guard, Rear	1

***NOTE: SOME "K" PARTS SHOWN ARE NOT PICTORIALY CORRECT**



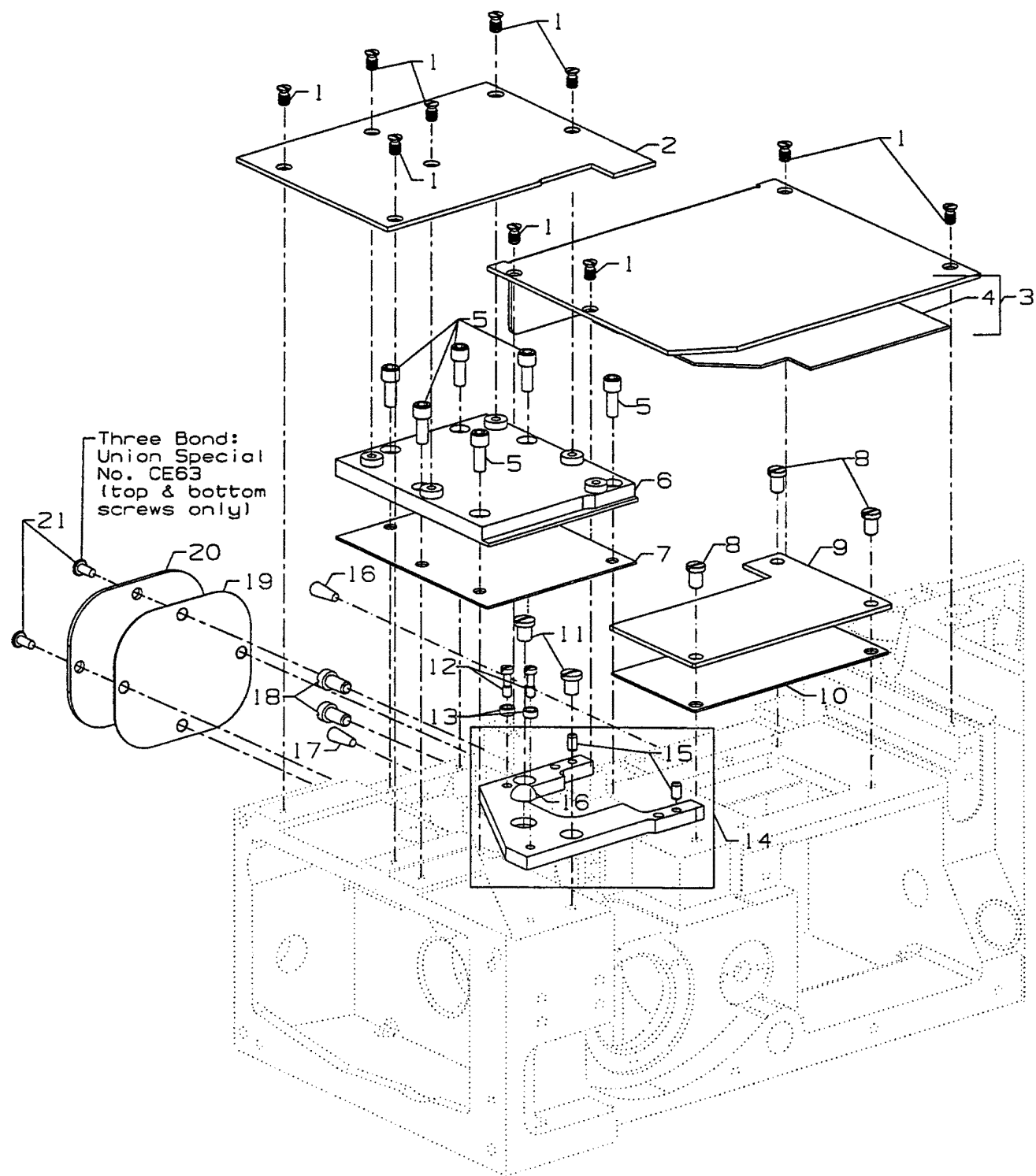

COVERS, LOWER BED

Ref. No.	Part No.	Description	Amt. Req.
1.	18-1448	Screw	11
2.	K74380	Cloth Plate, left	1
3.	50601E	Cloth Plate, right	1
4.	50303B	Acoustic Pad	1
5.	SS6121212TP	Screw, for cover	6
6.	50382CL	Cover, for feed chamber	1
7.	50382CS	Gasket	1
8.	22839C	Screw, for cover	3
9.	50382CG	Cover, for dry chamber	1
10.	50382CR	Gasket, for dry chamber cover	1
11.	SS7150740SP	Screw	2
12.	22587N	Screw	2
13.	35036AE	Ferrule, Locating	2
14.	K74391	Throat Plate Support, complete	1
15.	51280K	Pin	1
16.	660-939	Rubber Bumper, for Throat Plate Support	1
17.	C067D	Cork	2
18.	22517	Screw, for bed	2
19.	50382CR	Gasket	1
20.	50382CL	Cover, rear, for feed chamber,	1
21.	SS4120615SP	Screw, for cover	2
-	CE63	Three Bond Adhesive, (not shown), for screw	-

***NOTE: SOME "K" PARTS SHOWN ARE NOT PICTORIALY CORRECT**



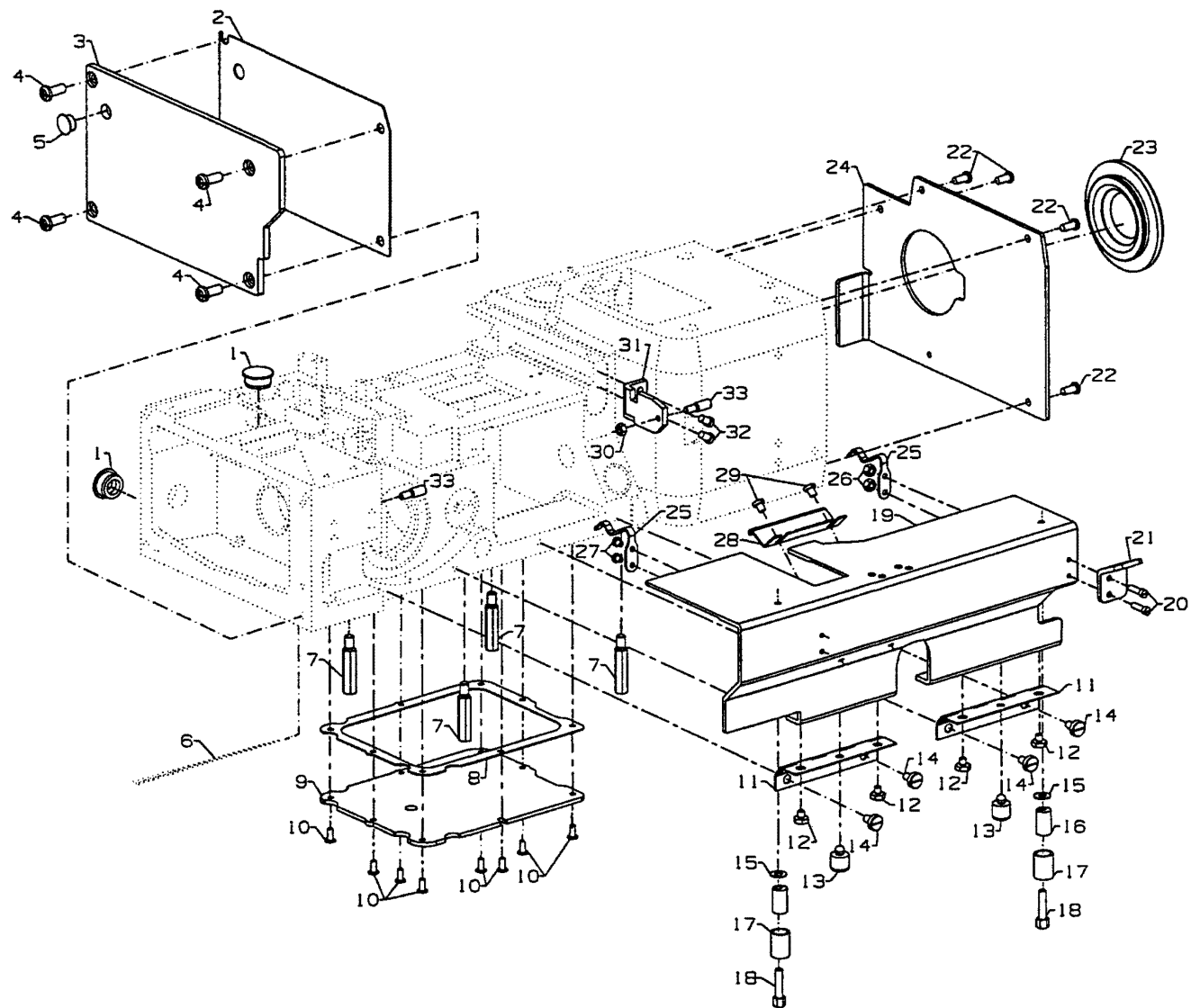

COVERS, LOWER BED

Ref. No.	Part No.	Description	Amt. Req.
1.	50393HB	Plug, for bed	2
2.	50684A	Quad Ring, for left end cover	1
3.	50682B	Left End Cover	1
4.	SS4151415SP	Screw	4
5.	50393HA	Plug	1
6.	WO3	Oil Wick, for needle guard	1
7.	22841U	Machine Support Stud	4
8.	50383G	Gasket, for chamber cover	1
9.	50382CG	Dry Chamber Cover	1
10.	SS7090850SP	Screw	8
11.	50378S	Hinge	2
12.	SS9110543CP	Screw	4
13.	660-1020	Rubber Bumper	2
14.	SS6120930TP	Screw	4
15.	20	Washer	2
16.	50382T	Stop, for front cover	2
17.	50393W	Rubber Bumper	2
18.	22519J	Screw	2
19.	K74379	Swing Down Cover	1
20.	22729D	Screw	2
21.	50667	Lever	1
22.	SS4121015SP	Screw	4
23.	50393HU	Plug, right end, non-synchronizer	1
24.	50382CJ	Cover, for drive belt	1
25.	50332A	Latch Spring	2
26.	39250J	Nut	2
27.	22513D	Screw	2
28.	50382FP	Latch, looper throw-out safety	1
29.	25CC	Screw	2
30.	35569J	Nut	1
31.	50332B	Support Block	1
32.	SS7120710SP	Screw	2
33.	22799AH	Spring Latch Stud	2

***NOTE: SOME "K" PARTS SHOWN ARE NOT PICTORIALY CORRECT**



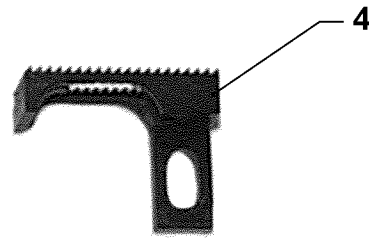
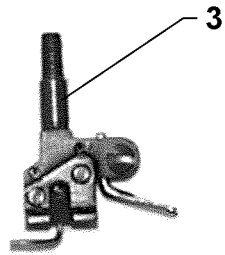
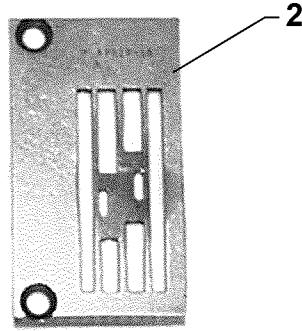
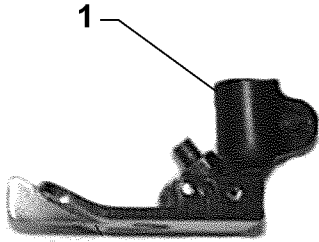

MODEL	NEEDLE HEAD	PRESSER FOOT ASSEMBLY	THROAT PLATE	FEED DOG
FS311L41-2H64Z4	K74395	50620PF64	A9820-16	51405AD12
FS311L41-2H64CC1Z3				

SEWING PARTS

Ref. No.	Part No.	Description	Amt. Req.
1.	50620PF64	Presser Foot	1
-	SS6060440TP	Screw	1
-	50630PF	Presser Foot Shank	1
-	91	Screw	1
-	51430F	Nut	1
-	22840A	Screw	1
-	50630PF64	Presser Foot Bottom	1
-	50630PF1	Guide	1
-	51430F	Nut	1
-	96651	Roll Pin	1
-	61330B44	Presser Foot Hinge Pin	1
2.	A9820-16	Throat Plate	1
3.	K74395	Needle Head	1
-	22KH	Screw	1
-	K74314	Thread Eyelet	1
-	28C	Set Screw	2
-	1096	Set Screw	1
-	50342Z	Needle Thread Guide	1
-	660-219AH	Roll Pin	2
4.	51405AD12	Feed Dog	1

***NOTE: SOME "K" PARTS SHOWN ARE NOT PICTORIALY CORRECT**



Union Special Corporation
Corporate Office
One Union Special Plaza
Huntley, IL 60142
Phone: 847•669•5101
Fax: 847•669•4454

Union Special GmbH
European Distribution Center
Raiffeisenstrasse 3
D-71696 Möglingen, Germany
Tel: 49•07141•247•0
Fax: 49•07141•247•100

JUKI CORPORATION
INTERNATIONAL SALES DIVISION
8-2-1, KOKURYO - CHO,
CHOFU-SHI, TOKYO 182, JAPAN
PHONE: 03(3430)4001-5
FAX: 03(3430)4909 . 4914 . 4984



JUKI
Union Special